

Tiles are all laid in the same direction.



Min. ambient temperature: 10 °C



Laying on extra-long double sided adhesive every 500m²

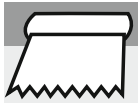

Min. surface temperature: 10 °C

Before laying the floor covering, it should be inspected, so as to detect any visual defects. In the event of any visual defects, please notify GERFLOR and do not start laying the product before receiving GERFLOR's approval.

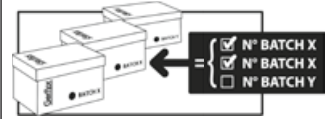

If laying GTI tiles in supermarkets (food stores), refer to the specific Laying Principle.

1. AREAS OF APPLICATION

FOREWORD: CONDITIONS FOR USE

1.1. LAYING TYPE

| | LAYING METHOD WITH TEMPERATURE CONDITIONS | PERIPHERAL EXPANSION |
|------------------|---|--|
| GTI PURE CONNECT | Since the premises are air-conditioned, the floor covering is not subject to temperature deviations greater than 20 °C. The dimensional stability of GTI PURE CONNECT tiles enables loose laying subject to a 500 m ² limit. | Due to the year-round heat regulation in the buildings, Gerflor recommends allowing for a 0.5 cm peripheral clearance. |

| DYNAMIC LOAD RESISTANCE | | | |
|--|--------------------------------------|--|---|
| Traffic frequency and type | Load according to tyre or wheel type | | |
| | Polyurethane or equivalent hardness | "Solid rubber or pneumatic tyre. This type of machine should not be left on the tiles when idle, so as to prevent dye migration. It should only be used for restocking shelves." | |
| GTI PURE CONNECT Routine frequency, typically store stocking and cleaning | Total load per wheel | | Electrically or thermally powered handling machinery is liable to give rise to heating-related damage due to wheel skidding. It is advisable to ensure that equipment is suitable for the floor covering structure (e.g.: machinery equipped with an anti-skid system) Paired wheels are counted as a single wheel when the distance between them (centre distance or track) is < 20 cm. Metal wheels are excluded. |
| | < 600 kg | < 1,000 kg | |
| | Contact pressure | | |
| | < 40 kg/cm ² | Not applicable | |
| | Total loaded weight | | |
| | < 1,800 kg | < 3,000 kg | |
| | Speed | | |
| | < 5 km/h | < 10 km/h | |
| | Handling | | |
| Hand-operated truck, manual or electric pallet truck with on-board operator, nominal capacity 1,300 kg | Traction truck | | |
| Cleaning | | | |
| Self-propelled automatic scrubbing machine with on-board operator | | | |

| STATIC LOAD RESISTANCE | | |
|------------------------|-------------------------|--------------------------------|
| | MAXIMUM LOAD PRESSURE | HANDLING MACHINERY EQUIVALENCE |
| GTI PURE CONNECT | < 40 kg/cm ² | < 500 kg /Wheel or per support |

IMPORTANT :

Due to the broad selection of handling machinery, consoles and floor scrubbing machines, it is necessary to account for the various factors listed above. For this reason, it is important to know the geometry of the console legs, the wheel type and configuration (single or double), the hardness values and the handling method (with or without on-board operator, speed, acceleration and braking mode).

Before laying the floor covering, it should be inspected, so as to detect any visual defects.

In the event of any visual defects, please notify GERFLOR and do not start laying the product before receiving GERFLOR's approval.

1.2 - TYPE OF PREMISES AND USE

This floor covering is particularly suitable for areas subject to heavy traffic in clean rooms, and production, storage and handling areas. It is not suitable for humid areas (showers, etc.). It must be applied in temperature-regulated premises (store, retail area, etc.).

1.3 - ELIGIBLE SUBSTRATES

For renovation, if more than 10% of the existing flooring is in bad condition, complete removal is necessary followed by new substrate preparation.

1.3.1 Preparatory work for concrete subfloor

MECHANICAL PREPARATION: The surfaces should be prepared with care so as to remove any soiling, laitance, treatment products or any other foreign bodies.

BUMP AND DEPRESSION TREATMENT: Sanding of bumps.
Cleaning: using industrial vacuum cleaner
Point levelling of depressions with suitable floor sealer.

CRACK TREATMENT:
On any surface, cracks should be detected beforehand. They are not treated, if they are flush, and if they are < 3 mm wide.

JOINT TREATMENT:
Contraction joint: If they have an opening < 4 mm, they are not treated.
Expansion joint: Following thorough cleaning, expansion joints are

preserved: end profiles with or without an overlay are arranged on either side of the joint.
Construction joint: Similar to cracks, if they have an opening < 1 mm, they are not treated.

LOCALISED LEVELLING:
Surface levelling may be required, particularly where the surface is not sufficiently even or in poor condition. A levelling compound with specifications meeting the usage requirements should be used. If the substrate moisture content is between 4 and 7%, we recommend the use of outdoor sealers (consult sealer manufacturers).

1.3.2 - Substrates

| NEW CONCRETE SUBSTRATE | |
|---|---|
| CONCRETE FLOOR | Surface evenness < 7 mm / 2 m or < 2 mm / 20 cm Follow subfloor preparation |
| RENOVATION | |
| CONCRETE FLOOR PAINTED CONCRETE | Surface evenness < 7 mm / 2 m or < 2 mm / 20 cm Follow subfloor preparation |
| TILES | Surface evenness < 7 mm / 2 m Unevenness < 1 mm Tile joints < 4 mm wide and < 1 mm deep, otherwise, fill them with a grouting product or levelling compound over the entire surface, so that the grouting joints are not visible (no telegraphing) |
| RESIN | Surface evenness < 7 mm / 2 m Treatment of cracks < 1 mm ; if > 1 mm, subfloor analysis is necessary Treatment of impacts > 10 mm with the same resin |
| PVC TILES AND COMPACT ROLLS | Damaged area: if less than 10% is in bad condition, remove the defective tiles and fill the gaps with levelling compound. Otherwise, complete removal is necessary followed by new substrate preparation. |
| RAISED FLOOR | The floor surface must not have any uneven areas > 2mm under 2m ruler, and the unevenness between two adjacent floor slabs must be < 1 mm. |
| GLUED PARQUET / LAMINATED FLOOR / FLOATING PARQUET OR WOOD BASED PANELS | Prohibited (complete removal) |
| OSB | Apply a fiber-reinforced levelling compound after treatment of any unevenness and joints between panels |
| WOOD-BASE PANEL FLOORING ON JOISTS OR BATTENS / PARQUET NAILED ON BATTENS VENTILATED UNDERNEATH | After treatment of any possible defects on the substrate (unevenness, open joints between planks or panels) |
| BITUMINOUS / ASPHALT | Surface evenness < 10 mm / 2 m, otherwise grind the bump. Static loading < 30 kg/cm ² , otherwise use load distribution plate |
| CARPET, LVT, PVC FOAM, LAMINATED FLOOR, LINOLEUM, OTHER WOOD-BASED PANEL | Complete removal |
| UNDERFLOOR HEATING | |
| UNDERFLOOR HEATING WITH CIRCULATING HOT WATER AT MAXIMUM 28° | Allowed |
| RADIANT ELECTRIC UNDERFLOOR HEATING THE REGULATIONS REQUIRE ≤ 0,15 M ² X ° KELVIN / WATT | Allowed if unevenness < 7 mm / 2 m and gluing mandatory on all the surface |
| LOW TEMPERATURE WATER REVERSIBLE UNDERFLOOR HEATING | Allowed |
| If the substrate is not in this list: please contact us. | |

2. LAYING

2.1 - STORAGE & WORK CONDITIONS

Before laying the floor covering, it should be inspected, so as to detect any visual defects. In the event of any visual defects, please notify GERFLOR and do not start laying the product before receiving GERFLOR's approval.

Since the stores are air-conditioned, these tiles are not subject to temperature deviations greater than 20 °C. The tiles should be stored on-site for 24 to 48 hours beforehand at ambient temperature.

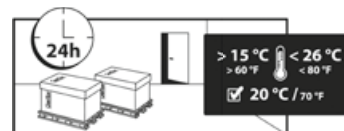

⚠ DO NOT MIX BATCHES

2.2- LAYING TYPE

GTI PURE CONNECT tiles can be bonded, but they are essentially intended for loose (non-adhesive) laying, in single pieces limited to 500 m². For larger surface areas, the surface is split into 500 m² sections and the joints between areas are sealed with adhesive.

2.3 -DETAILED LAYING

2.3.1 Extra-wide double-sided adhesive positioning

Division of surfaces into 500 m² sections

Since loose laying is limited to 500 m², it is necessary to envisage splitting into 500 m² sections by previously applying an extra-wide double-sided adhesive or acrylic glue on a width of two tiles.

In case of installation on long length (hallways, corridors...), double-sided adhesive or acrylic glue should be applied, never exceeding more than **20 rows** of tiles.

• Example of configuration < 500 m²

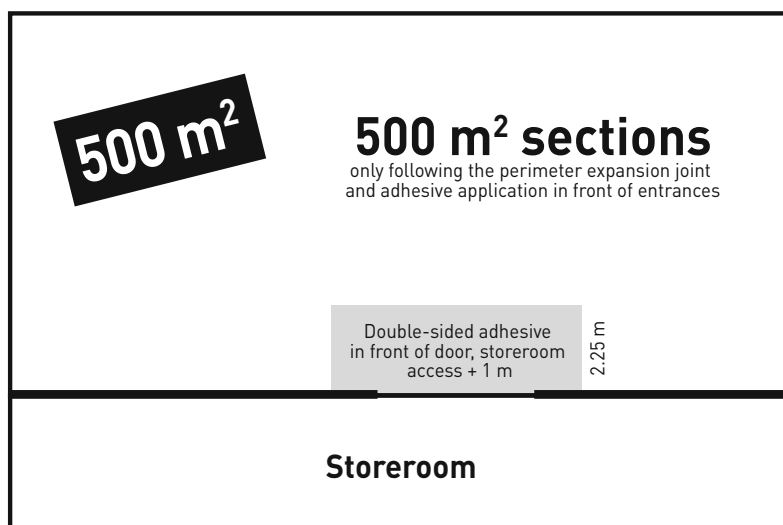

Each 500 m² section may include turning or liquid areas, storeroom entrances, also requiring double-sided adhesive application. Avoid locating 500 m² demarcation areas in a main aisle.

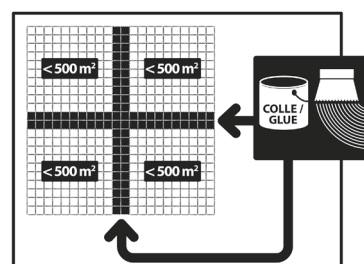

| SUPPORT | PRIMER | TYPE OF ADHESIVE |
|---|---|---------------------------|
| Hydraulic cement Dryness ≤ 4% moisture (CCM) | Grip A700 (BOSTIK) P121 / F78 / Seal Concrete (F BALL) Tec 049 (HB FULLER) Eco Prim T (MAPEI) | Fix&Free 740 from Gerflor |
| Hydraulic cement Dryness: Moisture content between 4% and 7% (CCM) | F78 (F BALL) EPOXY PE 480 UZIN | Fix&Free 740 from Gerflor |
| | Two-component polyurethane adhesive (with associated primer) KR 430 (UZIN) - G19 (MAPEI) | |
| Tiles | Levelling compound required. For the application of primer on levelling compound, refer to Hydraulic cement | Fix&Free 740 from Gerflor |
| Resin, old PVC covering | Stripping is necessary to remove any cleaning product. | |
| There are other primers recommended by glue manufacturers. | | |
| Gerflor only recommends to refer to the technical data sheets of these primers for their instructions. | | |
| If the substrate is not in this list: please contact us. | | |

2.3.2 Double-sided adhesive application

• Note on surface:

The surface should be dry, hard, perfectly adherent, load-bearing, plane and free from grease, dust & silicone.

• Dry adhesive application:

- Unroll the double-sided adhesive, pressing lightly on the adhesive with a gluing block
- Important:** The strongly adhesive (protected) side must never rest on the surface!
- Only unroll the amount of double-sided adhesive that can be covered that day with the floor covering.
- Roll up the remaining with the protective paper (to protect the surface and the section from dust).



• Laying PVC tiles on adhesive:

- Mark the lines on the protective paper either with a chalk line or a pencil.
- Mark the starting point of the first tiles and the first row of tiles.
- Place a steel rule along the line and cut only the protective paper with a straight blade.
- Remove the protective paper from the double-sided adhesive, pulling straight and flat. The line created forms the starting line of the first tiles of the first row.
- Lay the tiles and interlock them.
- Stack the protective papers as you progress and then roll them up (minimises waste volume).
- Remove the protective paper as you progress, pulling straight and flat.
- If laying is discontinued, the protective paper may be put back in place to protect the double-sided adhesive.
- After laying, roll over the entire surface in a criss-cross pattern.



• Removing tiles and double-sided tape adhesive:

Double-sided adhesive allows you to remove the floor covering without leaving any trace of adhesive and without damaging the surface.

- Disengage the tiles.
- Starting in one corner, detach the double-sided adhesive from the surface.
- Remove the floor covering and double-sided adhesive by pulling at ground level.

Gluing in front of sunny area (Bay windows)

In order to prevent the floor temperature from reaching excessive values (60 °C or above), direct sunlight on the floor should be obscured by curtains, blinds or other suitable protection. Otherwise, maintain the covering with a suitable adhesive, such as two-part polyurethane (PU) adhesive or hybrid adhesive.

| | BOSTIK | MANG | SADER | CEGECOL | MAPEI | UZIN | F BALL |
|--|------------|------|-------|---------------------------------|----------------|--|---|
| Gluing in front of sunny area (bay windows...) or temperature range > 20°C | STIX P956* | | | SOL UR* CEGE Hybrid XTREM | Adesilex G 19* | KR 430* KE68 Hybrid glue Single component | F 49 Hybrid glue 2 components (PSA) Pressure Sensitive Adhesive |

* PU 2 components

2.3.3 Installation of GTI PURE CONNECT tiles

• Precautions

1- The tiles are supplied on pallets. Different batches must not to be mixed together.

2- Laying direction: Tiles are **ALL** laid in the same direction. Observe the direction indicated by the arrow on the back of the tile.

3- Pressed materials, such as GTI PURE CONNECT tiles, may have dimensional tolerances from one series to another or from one color to another which may vary by 1 mm.

In this case, the tiles can:

- Either not be able to fit: In this case, plan to cut the dovetails and weld the slabs with a double-sided adhesive on each side of the weld.
- Easy to fit together: In this case, you must also place a double sided adhesive wide on both sides to avoid any risk of unclipping over time.

• Implementation:

The installation of tiles on large surfaces must always be done by working on the two axes that have been drawn beforehand, either along a wall or between two zones of 500 m² (see drawing) or crosses in the middle of the room.

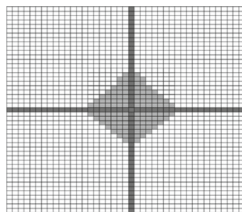

General case: Start crosswise in the middle of the room. Install the stair tiles ¼ by ¼ of the room.

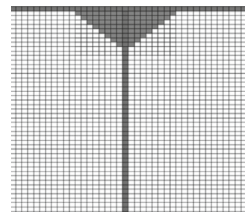

Implantation along a wall: Start in the middle of the implantation. Install the stair tiles on both sides.

- Lay in step for easier tile interlocking and to prevent displacement. The tiles are laid in step and **ALL** in the same direction (see arrows on back of tiles).

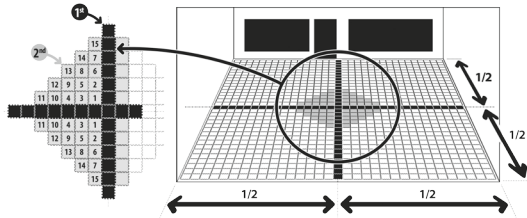

- **Interlocking of tiles (procedure, tools, etc.), adjustment**
 - The tiles are interlocked by striking with a synthetic mallet or a non-rebound mallet and a wooden block.
 - The tiles are interlocked from the corner to the edge.

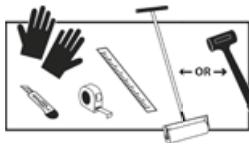

Tools required: Cutter - Tape measure - Metal rule - Metal tracing wheel - Wooden or synthetic resin mallet



Non-rebound mallet

| | | | |
|--------------------|-------|--|--|
| | ROMUS | | |
| Non-rebound mallet | 94964 | | |

- **Peripheral trimming**
The tiles should be positioned such that the peripheral cuts are $> \frac{1}{2}$ tile

Cutting (procedure, tools, etc.)

- Peripheral clearance: in standard sections, the peripheral clearance is 0.5 cm.
- Provide a circular saw with platform for the duration of the work.
- Cutting is performed either with a cutter (1 pass on the surface and repeat on the back), or using the transfer technique (scribing)
 - Scribing:* Method for tracing or cutting parallel lines. For this, a marking gauge or a tile gauge is used.
- Position the tile to be cut on the last full tile laid.
- Take a full tile which will serve as a gauge.
- Lay it on the tile to be cut, pressing on the partition (wall). Leave a clearance of 0,5 cm.
- Mark the tile to be cut along the edge of the gauge, with a cutter equipped with a straight blade.
- Cut the part of the tile to be laid neatly and put it in place.
- For difficult areas (door frame, etc.), use demultiplied shears.

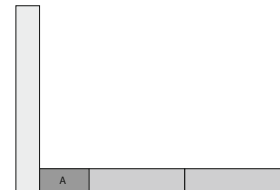
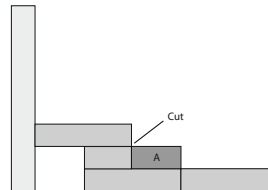

Mitre shears
Reference: Romus: 93401 / Janser: 237 530 000. For cutting around door frame bases, areas which are difficult to access.



Demultiplied mitre shears
Reference: Janser: 262 284 000. For cutting around door frame bases, areas which are difficult to access.

3. HANDLING SPECIAL SECTIONS

■ 3.1 - SKIRTING

VYNAFLEX skirting or Gerflor Flexible skirting for finishing between floor and wall.

■ 3.2 - SURFACE EXPANSION JOINTS

- Flush joints: The CJ 20-5 profile with PVC strips supplied by Romus covers the joint. Adhesive-free tiles are cut along the joint and should be welded onto the flexible joint.
- Joints with overlay profile: The profile is fitted over the floor covering and is secured on one side only.

■ 3.3 - DOORWAYS AND STOPS

Use the following profiles according to the conditions of use (intensity of traffic, humidity level, etc.).

3.3.1 Finishing profile 0505

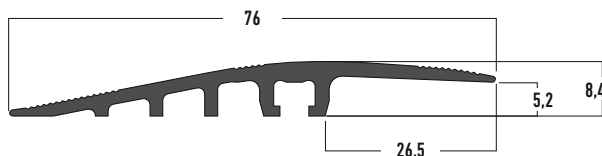

3 m long profile strip with 10 pre-drilled countersunk holes, 4.6 mm diameter.

The spacing between holes is 313 mm
The first hole is 90 mm from the end
The holes are de-burred after drilling

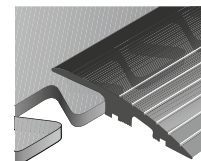

4 x 50 mm TFZ screws and 6 x 30 mm (supplied)

TFZ 4mm diameter screw,
50 mm long



6 mm diameter plug,
30 mm long



3.3.2 6mm PVC Ramp High Traffic (REF. 0500)

This ramp can be installed on tiles, concrete, resin and PVC flooring.

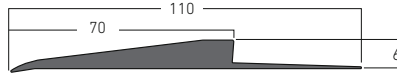

See Installation Guidelines [512] PVC ramp 6 mm High Traffic

3.3.3 GTI PURE DECOR Access and Corner

These accessories must be glued with two-component glue and weighted during the setting of the glue (6-12 hours).

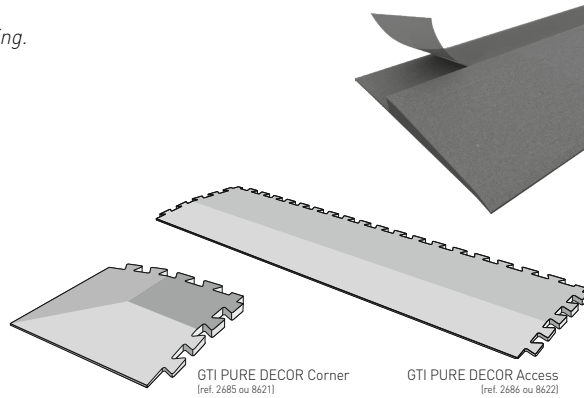

3.4 - SEALANT APPLICATION IN PERIPHERAL CLEARANCE

We recommend applying a polyurethane or hybrid sealant (M.S. Polymer) in the peripheral clearance to prevent any water or other penetration.

3.5 - CONNECTION TO ADJACENT FLOOR COVERINGS

Depending on the type of floor covering adjacent to the GTI PURE CONNECT tile, use the suitable profile in the Gerflor range.

3.6 - JOIN BETWEEN DIFFERENT COLOURED TILES

The tiles are joined by interlocking the different coloured tiles (most reliable solution) or by means of straight or rounded cutting and sealing (most visually appealing solution).

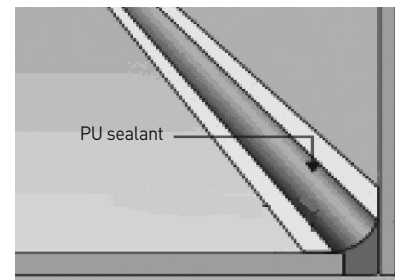

4. INSTALLATION OF FURNITURE

- Consoles (whether stocked or not) and other display units should be put back in place using distribution plates to prevent slippage of the loose laid material.
- Any damage to the material caused by putting fixtures back into place shall not be accepted by the installer or material manufacturer.

5. REPAIRS AND MAINTENANCE

5.1 - MONITORING, MAINTENANCE AND REPAIRS

The user should regularly monitor that the structure appears to be securely in place and notify the client and/or original installer of any anomalies that the user deems to incur potential risks in respect of the durability of the structure.

The technical analysis, requested by the user from the other parties, should differentiate between ageing due to normal wear and tear due to the traffic and use of the premises and accidental damage.

If the observations made by the user are found to be justified following the technical analysis, the installer shall conduct the repair work within the scope of its contractual and/or legal commitments.

NOTE:

As part of this monitoring, the user should report any accidents linked with the operation of the premises without delay for repairs, in particular: cuts due to falling sharp objects, individual burns, etc. This maintenance may be carried out by the user's maintenance department.

5.2 - REPLACING GTI PURE CONNECT TILES

- Replacing an adhesive-free tile:
 - Cut a corner of the damaged tile,
 - Disengage the dovetails,
 - Fit a new tile in place, observing the laying direction.
- Replacing an adhesive-bonded tile:
 - Cut a corner of the damaged tile,
 - Disengage the dovetails,
 - Cut and replace the adhesive,
 - Fit a new tile in place, observing the laying direction.

